

61006

- Includes One 8" Downrod
- Includes Remote Control
- Title 20
- Color Tunable
- Wifi Enabled



Job Name : _____
 Job Type : _____
 Quantity : _____
 Comments : _____



FCT6100WT (Remote Control)



FANDELIGHT™
 Magnetically Connect to Wall Plate.
 Light Dimming.
 Battery Operated.
 *CCT tuning on select SKU's

PRODUCT DESCRIPTION

The Solstice Fandelight houses a Wifi-enabled fan within a cage of artfully bent Satin Nickel channels to create a classic form in light. The Smart control functions operate both the fan and the light itself. Adjust the color temperature and light intensity by use of the remote provided or Smart Home apps without the use of a gateway.

- Always consult a qualified electrician before installing any lighting product
- Installation Requirements:
 Ceiling fan attaches to electrical junction box securely anchored and capable of withstanding at least 35 lbs

FINISHES OPTION

 Satin Nickel

MATERIAL

Aluminum+Steel+ABS

RATINGS

cETLus
 Damp Location

INCLUDES

- Wall Mountable Remote Control
- 1 x 8" Downrod

DOWNROD OPTIONS

- 18" (FRD0118SN)
- 24" (FRD0124SN)
- 30" (FRD0130SN)
- 36" (FRD0136SN)



ADDITIONAL

RATED LIFE: 35,000 Hours
 OPERATING TEMPERATURE: -20°C (-4°F), 40°C (104°F)
 LIGHTING DIRECTION: Up

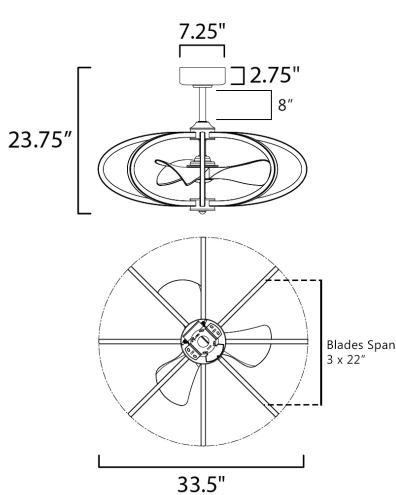

MEASUREMENTS

DIMENSION : 33.5" D x 23.75" H
 BLADES : 3 x 22"
 MAX OAH : 23.5" OAH
 CANOPY : 7.25" W x 2.75" H x 7.25" L
 HANGING WEIGHT : 19.4 lb

LAMPING

INPUT VOLTAGE : 120V
 LUMENS : 6,640 Rated (4,320 Del.)
 BULB : 60W LED PCB Intergrated, 60W Total
 DIMMABLE : By Control Provided
 CRI : 80+ CRI
 COLOR_TEMP : 2700-4000K

ENERGY INFORMATION AT HIGH SPEED

AIRFLOW : 2600 CFM
 ELECTRICITY USE : 20W
 AIRFLOW EFFICIENCY : 130 CFM / W



WESTERN DISTRIBUTION CENTER (HEADQUARTER)
 253 NORTH VINELAND AVE | CITY OF INDUSTRY, CA 91746
EASTERN DISTRIBUTION CENTER
 101 GARDNER PARK | PEACHTREE CITY, GA 30269
 P. 626.956.4200 | F. 626.956.4225 | maximlighting.com