

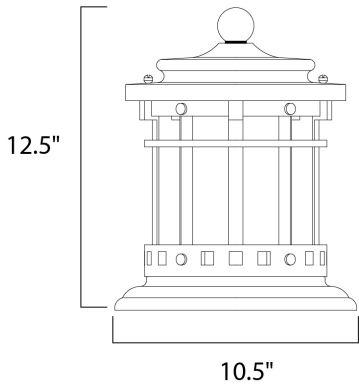

PRODUCT DESCRIPTION

Santa Barbara EE is a traditional, craftsman/mission style, energy saving collection from Maxim Lighting International in Sienna finish with Mocha glass.



MEASUREMENTS

DIMENSION : 10.5" W x 12.5" H
 HANGING WEIGHT : 5.28 lb

LAMPING

INPUT VOLTAGE : 120V
 LUMENS : 1,355 Rated (0 Del.)
 BULB : 1 x 18W (INCLUDED), 18W Total
 CRI : 80+ CRI
 COLOR_TEMP : 2700K

FINISHES OPTION

Sienna SE



GLASS

Mocha MO

MATERIAL

Die Cast Aluminum

RATINGS

Wet Location



ADDITIONAL

INSTALL UP/DOWN:
 INCANDESCENT WATTS: 123
 RATED LIFE 10000 Hours
 OPERATING TEMPERATURE:
 -20°C (-4°F), 40°C (104°F)

Always consult a qualified electrician before installing any lighting product.



WESTERN DISTRIBUTION CENTER (HEADQUARTER)
 253 NORTH VINELAND AVE | CITY OF INDUSTRY, CA 91746
EASTERN DISTRIBUTION CENTER
 4200 SHIRLEY DR. | ATLANTA, GA 30336
 P. 626.956.4200 | F. 626.956.4225 | maximlighting.com