

PRODUCT DESCRIPTION

Inglenook is a transitional style collection from Maxim Lighting International in Burnished with Iridescent glass.

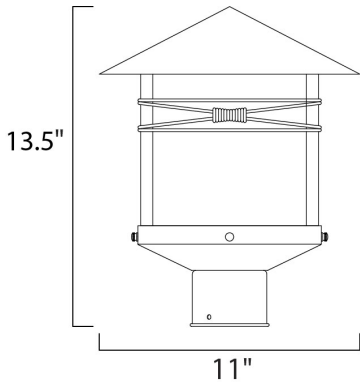

MEASUREMENTS

DIMENSION : 11" W x 13.5" H
 HANGING WEIGHT : 5.94 lb

LAMPING

LUMENS : 1,150 Rated
 BULB : 1 x 100W Incandescent MB , 0W Total
 BULB INCLUDED : (Not Included)
 DIMMABLE : Yes
 COLOR_TEMP : 2700K

FINISHES OPTION

-  Burnished
-  Country Stone
-  Pewter

GLASS

Iridescent IR

MATERIAL

Stainless Steel + Art Glass

RATINGS

cETLus
 Wet Location



ADDITIONAL

RATED LIFE 2500 Hours
 OPERATING TEMPERATURE:
 -20°C (-4°F), 40°C (104°F)

Always consult a qualified electrician before installing any lighting product.



WESTERN DISTRIBUTION CENTER (HEADQUARTER)
 253 NORTH VINELAND AVE | CITY OF INDUSTRY, CA 91746

EASTERN DISTRIBUTION CENTER
 4200 SHIRLEY DR. | ATLANTA, GA 30336

P. 626.956.4200 | F. 626.956.4225 | maximlighting.com