

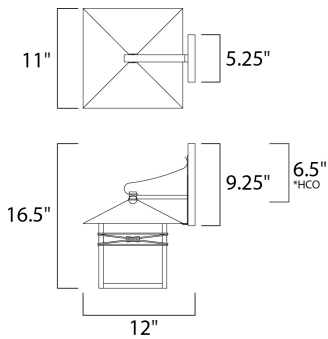

PRODUCT DESCRIPTION

Inglenook is a transitional style collection from Maxim Lighting International in Burnished with Iridescent glass.



MEASUREMENTS

DIMENSION : 11" W x 16.5" H x 12" Ext
 BACK PLATE : 5.25" W x 9.25" H x 6.5" HCO
 HANGING WEIGHT : 6.16 lb

LAMPING

LUMENS : 1,150 Rated
 BULB : 1 x 100W Incandescent MB , 100W Total
 BULB INCLUDED : (Not Included)
 DIMMABLE : Yes
 COLOR_TEMP : 2700K

*height from center of outlet to the top of the fixture

FINISHES OPTION

-  Burnished
-  Country Stone
-  Navaho White
-  Pewter

MATERIAL

Stainless Steel + Art Glass

RATINGS

cETLus
 Wet Location



ADDITIONAL

RATED LIFE 2500 Hours
 OPERATING TEMPERATURE:
 -20°C (-4°F), 40°C (104°F)

Always consult a qualified electrician before installing any lighting product.



WESTERN DISTRIBUTION CENTER (HEADQUARTER)
 253 NORTH VINELAND AVE | CITY OF INDUSTRY, CA 91746
EASTERN DISTRIBUTION CENTER
 4200 SHIRLEY DR. | ATLANTA, GA 30336
 P. 626.956.4200 | F. 626.956.4225 | maximlighting.com