

**PRODUCT DESCRIPTION**

Maxim Lighting's commitment to both the residential lighting and the home building industries will assure you a product line focused on your basic lighting needs. With the Newport collection you will find quality lighting that is well designed, well priced and readily available.

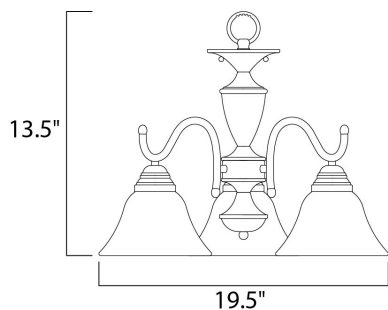

**MEASUREMENTS**

DIMENSION : 19.5" W x 13.5" H  
 HANGING WEIGHT : 6.13 lb

**LAMPING**

LUMENS : 3,450 Rated  
 BULB : 3 x 100W Incandescent E26 Medium , 300W Total  
 BULB INCLUDED : (Not Included)  
 DIMMABLE : Yes  
 COLOR\_TEMP : 2700K

**FINISHES OPTION**

 Oil Rubbed Bronze  
 Satin Nickel

**GLASS**

Wilshire WS

**MATERIAL**

Iron

**RATINGS**

cETLus  
 Dry Location

**ADDITIONAL**

RATED LIFE 2500 Hours  
 OPERATING TEMPERATURE:  
 -20°C (-4°F), 40°C (104°F)

Always consult a qualified electrician before installing any lighting product.



**WESTERN DISTRIBUTION CENTER (HEADQUARTER)**  
 253 NORTH VINELAND AVE | CITY OF INDUSTRY, CA 91746

**EASTERN DISTRIBUTION CENTER**  
 4200 SHIRLEY DR. | ATLANTA, GA 30336

P. 626.956.4200 | F. 626.956.4225 | maximlighting.com