

PRODUCT DESCRIPTION

Classic straight lines and large scale makes this collection an excellent candidate for light commercial applications. Dual LED downlights are encased in each rectangular front which is finished in a dark Bronze and contrasted nicely with a soft white Linen shade. This collection is 100% LED for low maintenance and energy efficiency.

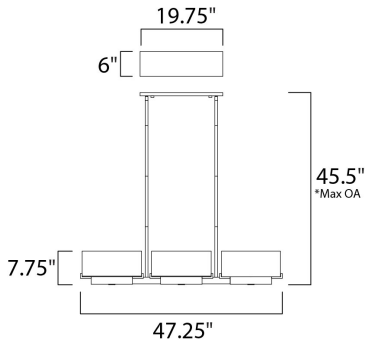

*max overall height

MEASUREMENTS

DIMENSION : 47.25" L x 13.75" W x 7.75" H
 MAX OAH : 45.5" OAH
 CANOPY : 6" W x 0.75" H x 19.75" L
 HANGING WEIGHT : 26.62 lb

LAMPING

INPUT VOLTAGE : 120V
 LUMENS : 5,740 Rated
 BULB : 8 x 9W LED LED , 72W Total
 BULB INCLUDED : (Included)
 DIMMABLE : Triac CL
 CRI : 90+ CRI
 COLOR_TEMP : 3000K

FINISHES OPTION

 Dark Bronze (DBZ)

MATERIAL

Steel

RATINGS

Dry Location



ADDITIONAL

ADJUSTABLE
 OPERATING TEMPERATURE:
 -20°C (-4°F), 40°C (104°F)

Always consult a qualified electrician before installing any lighting product.



WESTERN DISTRIBUTION CENTER (HEADQUARTER)
 253 NORTH VINELAND AVE | CITY OF INDUSTRY, CA 91746

EASTERN DISTRIBUTION CENTER
 101 GARDNER PARK | PEACHTREE CITY, GA 30269

P. 626.956.4200 | F. 626.956.4225 | maximlighting.com