



PRODUCT DESCRIPTION

Urban Nights is a chic collection in perfect sync with on-trend transitional styles. Each fixture fuses modern geometric forms with frosted glass cylinders, illuminated by Xenon bulbs to create a two-way light source. Underneath the frame, LED downlights provided the second source of light. Urban Nights is available in a linear or circular black metal base with luminous cylinders set at various heights for visual movement.

MEASUREMENTS

DIMENSION : 28.25" L x 28.25" W x 21.25" H
 MAX OAH : 68" OAH
 CANOPY : 4.25" W x 1.5" H x 4.25" L
 HANGING WEIGHT : 44 lb

LAMPING

INPUT VOLTAGE : 120V
 LUMENS : 4,930 Rated (3,451 Del.)
 BULB : 28 x 25 + 2.5W Xenon + LED LED , 610W Total
 BULB INCLUDED : (Included)
 DIMMABLE : Electronic Low Voltage (ELV)
 CRI : 80+ CRI
 COLOR_TEMP : 3000K

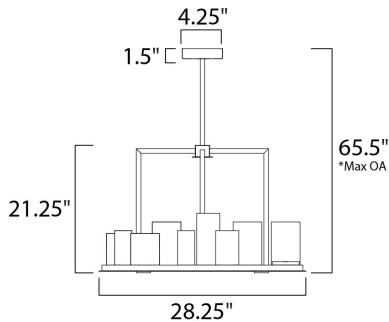

*max overall height

FINISHES OPTION

 Textured Black (TXB)

GLASS

Frosted FT

MATERIAL

Steel

RATINGS

Dry Location



ADDITIONAL

RATED LIFE 2000 Hours
 OPERATING TEMPERATURE:
 -20°C (-4°F), 40°C (104°F)

Always consult a qualified electrician before installing any lighting product.



WESTERN DISTRIBUTION CENTER (HEADQUARTER)
 253 NORTH VINELAND AVE | CITY OF INDUSTRY, CA 91746
 EASTERN DISTRIBUTION CENTER
 101 GARDNER PARK | PEACHTREE CITY, GA 30269
 P. 626.956.4200 | F. 626.956.4225 | maximlighting.com